

A	mm	4635
B	mm	1070
C	mm	2750
D	mm	815
E	mm	4100
F	mm	480
H	mm	2220
M	mm	940
P	mm	2440
R	mm	3920
S	mm	4780
T	mm	3710
Z	mm	850

* Internal width

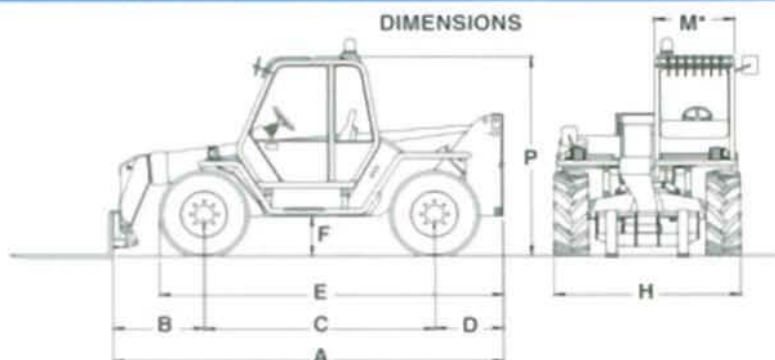

OUTSTANDING MANOEUVRABILITY

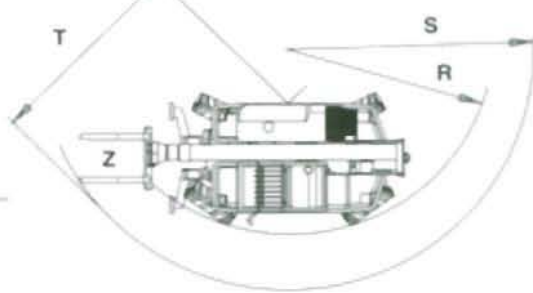

WEIGHTS

Machine weights with forks kg 7600

PERFORMANCES

Max. lift capacity	kg	4000
Max. lift height	mm	8240
Max. reach	mm	4300
Max. height at full capacity	mm	6500
Max. reach at full capacity	mm	1350
Max. capacity at full height	kg	3000
Max. capacity at full reach	kg	1300
Tear-out force with 800 l bucket	kg	4970
Drawbar pull	kg	5850
Carriage rotation	deg	140

OPERATING TIMES

Boom lift	sec	10.5
Boom lower	sec	12
Boom extend	sec	10
Boom retract	sec	7.5
Full carriage tilt	sec	5
800 l bucket dump	sec	1.5

TRAVEL SPEED

1st gear	kph	7
2nd gear	kph	25

P 40.8 EVS

Lift capacities at 500 mm load centre

FEM 4001r
EN 1459 Annex B

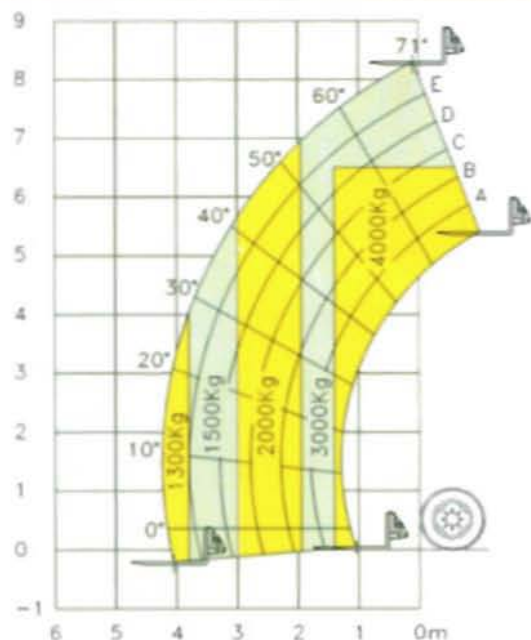

OPERATOR'S CAB

Structure complies with EEC directives 86/295 (ROPS) and 86/296 (FOPS). The cab is mounted on rubber antivibration blocks and fitted with noise dampening panels. Front and rear screens are fitted with wipers and can be opened for additional ventilation. Boom and carriage are operated by "2 in 1" joystick levers. Instrumentation includes tachometer/revolution counter, hour meter, fuse box, check-control panel showing blocked engine air filter, hydrostatic oil level and temperature, engine oil pressure, coolant temperature, parking brake warning light. Centralized pressure test gauge. Also as standard is a cab heater/demister/pressurisation system and a courtesy light.

SAFETY SYSTEMS

A safe load warning device activates both audio and visual signals and locks overloading actions. Automatic lock of frame levelling when boom exceeds the safety angle. Safety lock valves are incorporated in all hydraulic cylinders. A reversing bleeder is fitted. Engine cover lock. Fire extinguisher couplings in the cab. Safety belts.

BOOM SIDE-SHIFT

A MERLO patented chassis side-shift is fitted allowing ± 110 mm of carriage side-shift with boom fully retracted or ± 205 mm if boom is fully extended.

BOOM

A two section boom made from high yield steel and telescoping on anti-friction externally adjusted pads. The extension cylinder is protected by mounting inside the boom.

CARRIAGE

A "Tac-Lock" carriage (for attachment of equipments from inside the cab) is fitted with two hydraulic service lines making a double acting service.

PALLET FORKS

1200 mm long, section 130 x 45 mm. Centre to centre fork distances, hand adjustable, from 450 to 1050 mm.

FRAME LEVELLING

A hydraulic activated tilt device allows chassis and boom levelling under any ground conditions.

STEERING

Hydraulically powered with wheel automatic resynchronization in case of misalignment.

Three steering modes.

- All wheel steer
- Front wheel only steer
- Crab steer

ENGINE

Low emission (97/68/CE) 4 cylinder Perkins 1004-42 Diesel engine with direct injection and water cooling, 61.5 kW at 2400 rpm (ISO 3046/1).

TRANSMISSION

Hydrostatic closed circuit type with automatic stepless speed regulation. Inching pedal. Two speed gearbox. Permanent four wheel drive through differential and hub reduction gears. Front axle is mounted rigidly, the rear axle oscillates. Dropped hubs of the crown and pinion reduction type for improved ground clearance.

BRAKES

Hydraulically activated disc brakes on all four wheels.

mounted on differential output shafts.

Fail-safe parking disc brake hydraulically controlled on main propshaft.

SERVICE HYDRAULICS

Single axial piston pump at variable delivery, "Load-Sensing" control. Maximum flow: 120 l/min. Operating pressure: 210 bar. 125 micron "For-Life" strainer on suction line. 40 micron filter on return line.

ELECTRICS

12 V system with 110 Ah battery and 65 A alternator. Full road lighting and flashing beacon.

CAPACITIES

Hydraulic oil: 95 l
Diesel fuel: 155 l
Hydrostatic oil: 12 l
Engine oil: 8.5 l
Coolant: 12 l

TYRES

16/70-20 14 PR on both axes, mounted on 8 stud disc rims (DIN 74361).

OPTIONS

Low emission turbo charged engine (97/68/CE), 80.4 kW at 2400 rpm (ISO 3046/1) and 40 kph high speed transmission. Rear differential lock. Rear PTO. Air conditioning. 16/70-20 14 PR semi-industrial profile tyres. "5 in 1" electronic joystick. Roof window wiper. Front screen guard. Pre-arrangement for mixing shovel.

MERLO

MERLO UK LTD - Padlocks Headlands Business Park - Salisbury Road
RINGWOOD - HAMPSHIRE - BH24 3PB - ENGLAND

Tel: (01425) 480806/470701 - Fax: (01425) 477478 - www.merlo.co.uk

MERLO SPA Industria Metallmeccanica - 12020 S. DEFENDENTE DI CERVASCA (CN) - ITALY

Tel: + 390171-614111 - Fax: 390171-614100 - Telex: 220236 Merlo - www.merlo.com - E-mail: info@merlo.com



F141G

00