

MERLO

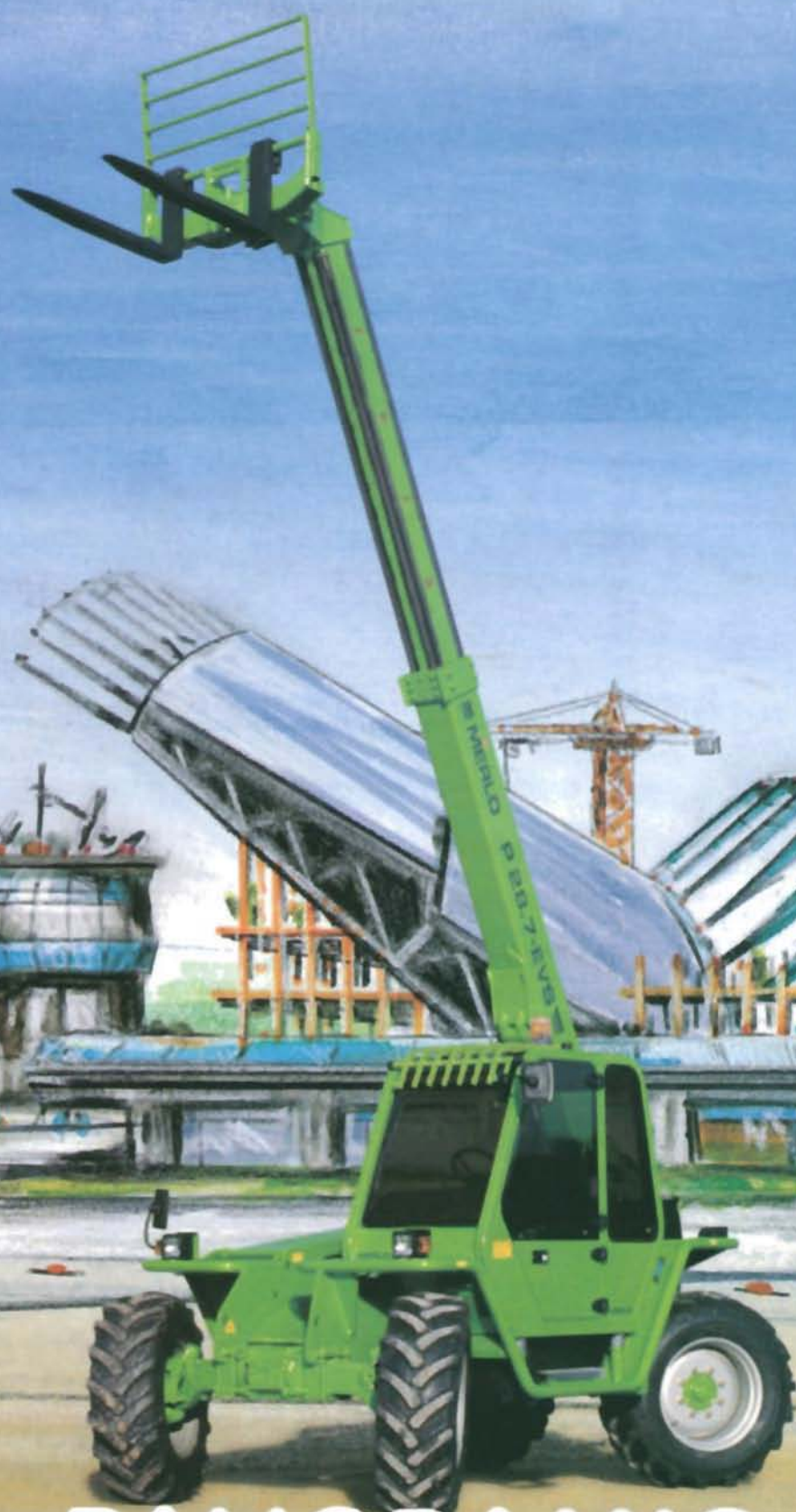

**PANORAMIC
P 28.7 EVS**

A	mm	4 170
B	mm	880
C	mm	2 700
D	mm	570
E	mm	3 960
F	mm	565
H	mm	2 230
M	mm	940
P	mm	2 465
R	mm	3 700
S	mm	4 740
T	mm	3 560
Z	mm	850

* Internal width

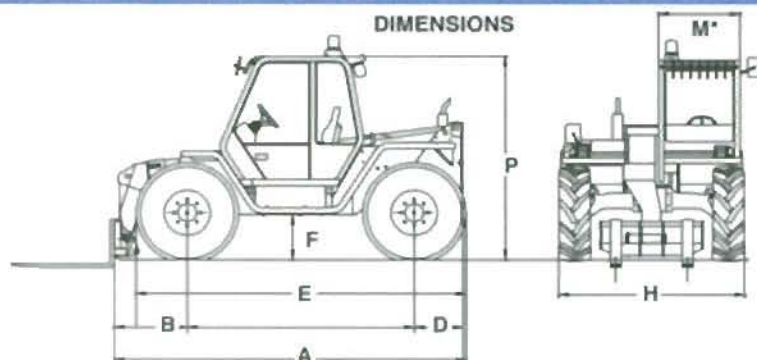

OUTSTANDING MANOEUVRABILITY

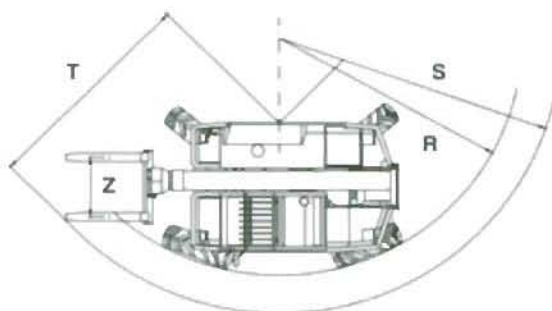

WEIGHTS

Machine weights with forks kg 6650

PERFORMANCES

Max. lift capacity	kg	2800
Max. lift height	mm	6950
Max. reach	mm	3580
Max. height at full capacity	mm	6250
Max. reach at full capacity	mm	1550
Max. capacity at full height	kg	2500
Max. capacity at full reach	kg	1100
Tear-out force with 800 l bucket	kg	4300
Drawbar pull	kg	5330
Carriage rotation	deg	140

OPERATING TIMES

Boom lift	sec	8
Boom lower	sec	7
Boom extend	sec	6.5
Boom retract	sec	5
Full carriage tilt	sec	5
800 l bucket dump	sec	1.5

TRAVEL SPEED

1st gear	kph	7
2nd gear	kph	25

28.7 EVS

Lift capacities at 500 mm load centre

FEM 4001r
pr EN 1459 Annex B

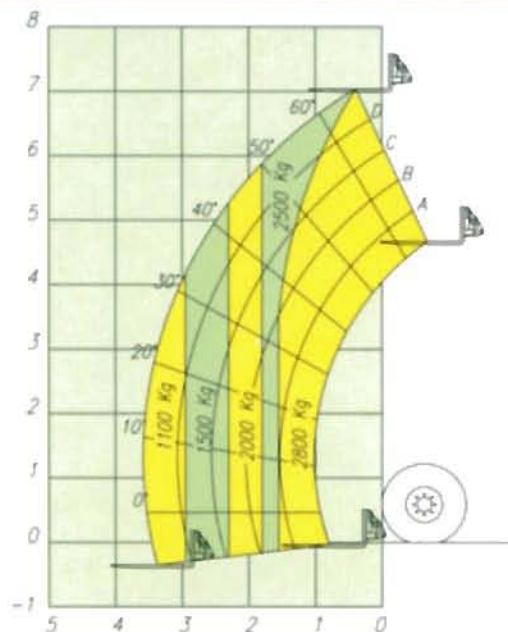

OPERATOR'S CAB

Structure complies with EEC directives 86/295 (ROPS) and 86/296 (FOPS).

The cab is mounted on rubber antivibration blocks and fitted with noise dampening panels. Front and rear screens are fitted with wipers. Boom and carriage are operated by "3 in 1" joystick lever.

Instrumentation includes: Tachometer/Revolution counter, hour meter, fuse box, coolant liquid thermometer, check-control panel showing blocked engine air filter, hydrostatic oil level and temperature, engine oil pressure, coolant temperature, parking brake warning light.

Centralized pressure test gauge. Also as standard is a cab heater/demister/pressurisation system and a courtesy light.

SAFETY SYSTEMS

A safe load warning device activates both audio and visual signals and locks overloading actions. Safety lock valves are incorporated in all hydraulic cylinders.

A reversing beeper is fitted.

Engine hood lock.

Fire extinguisher couplings in the cab.

Safety belts pre-arrangement.

BOOM

A two section boom made from high yield steel and telescoping on anti friction externally adjusted pads.

The extension cylinder is protected by mounting inside the boom.

CARRIAGE

A "TAC-LOCK" carriage (for attachment of equipments from inside the cab), is fitted with two hydraulic service lines making a double acting service.

PALLET FORKS

1200 mm long, section 130 x 45 mm.

Centre to centre fork distances, hand adjustable, from 450 to 1050 mm.

STEERING

Hydraulically powered with wheel automatic resynchronization in case of disalignment.

Three steering modes:

- All wheel steer
- Front wheel only steer
- Crab steer

ENGINE

4 cylinder PERKINS 1004-4 Diesel engine with direct injection and water cooling 62 kW (84 Hp) at 2400 rpm (DIN 70020).

TRANSMISSION

Hydrostatic closed circuit type with automatic stepless speed regulation.

Inching pedal.

Two speed gearbox with hydraulic control.

Permanent four wheel drive through differential and hub reduction gears.

Front axle is mounted rigidly, the rear axle oscillates.

Dropped hubs of the crown and pinion reduction

type for improved ground clearance.

BRAKES

Hydraulically activated disc brakes on all four wheels, mounted on differential output shafts. Fail-safe parking disc brake hydraulically controlled on main propshaft.

SERVICE HYDRAULICS

Gear pump.

Maximum flow: 91 l/min

Operating pressure: 210 bar

40 micron filter on return line.

ELECTRICS

12 V system with 110 Ah battery and 65 A alternator.

Full road lighting and flashing beacon.

Electric cable inside the boom to supply a electric socket at its end (12 V - 10 A).

CAPACITIES

Hydraulic oil: 95 l - Diesel fuel: 155 l

Hydrostatic oil: 12 l - Engine oil: 8.5 l

Coolant: 12 l

TYRES

405/70-24 14 PR on both axles, mounted on 8 stud disc rims (DIN 74361).

OPTIONS

Front and rear differential lock.

Rear PTO. Front screen guard.

Pre-arrangement for rear excavator and mixing shovel.

MERLO

MERLO UK LTD · Paddocks Headlands Business Park · Salisbury Road

RINGWOOD · HAMPSHIRE · BH24 3PB · ENGLAND

Tel: (01425) 480806/470701 · Fax: (01425) 477478 · www.merlo.com.uk

MERLO SPA Industria Metallmeccanica - 12020 S DEFENDENTE DI CERVASCA (CN) - ITALY

Tel: +39 0171-614111 · Fax: +39 0171-614100 · Telex 220236 Merlo I · www.merlo.com · E-mail: info@merlo.com